

Part NO. SS-GLE2540P274B3/SS012	Type GPS&GLONASS External Active Antenna
--	--

Electrical Characteristics

Antenna

1	Antenna model	25*25*4mm	
2	Frequency Range	1575.42MHz±1.023MHz	1598.06MHz~1605.38MHz
3	V.S.W.R	1.5 max	1.5 max
4	Band With@RL=-10dB	>10MHz	>10MHz
5	Gain@Zenith	5dBi@70*70mm Gtound	5dBi@70*70mm Gtound
6	Impedance	50 Ω	
7	Polarization	RHCP	
8	Axial Ratio@Zenith	<8dB	<10dB

LNA

1	Frequency Range	1555MHz~1580MHz		
2	DC Voltage	1.5V(min)	3.0V(typ)	3.6V(max)
3	DC current	7.3mA	8.5mA	10.0mA
4	Noise Figure	1.1<		
5	LNA Gain	31dB@25°C,1575.42MHz; 30dB@25°C,1602MHz		
6	VSWR	2.0 max		

Material

No	Part Name	Spec
1	Radome Material	ABS
2	Antenna	Dielectric Ceramics
3	Ground	0.8mm, FR-4
4	Cable	L=3m, RG-174
5	Connector	SMA-J (Male)

Environment Condition

1	Working Temp	-40°C ~+85°C, 10%~95% RH
2	Storage Temp	-45°C ~+90°C, 10%~95% RH
3	Ingress Protection	IP67

Dimensions

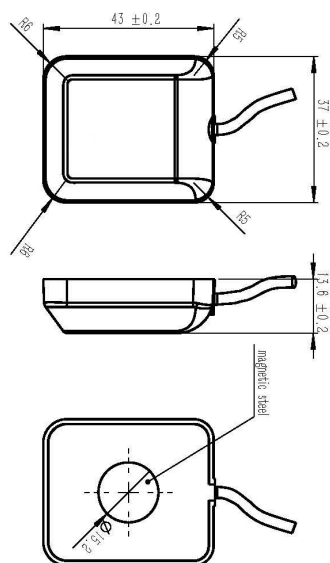

LNA Gain @3.0V

